

12 m = 120 cm
10 m = 100 cm
9 m = 90 cm
6-8 m = 80 cm

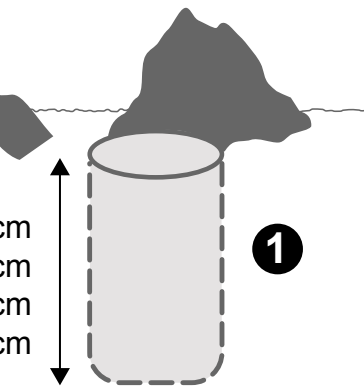

1

12-10 m = Ø 40 cm
6-9 m = Ø 30 cm

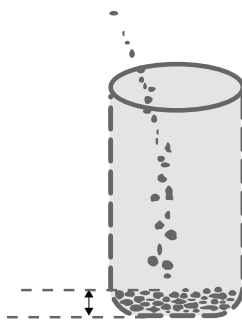

2

Täida põhi 5 cm paksuselt
killustikuga. Seejärel täida
auk betooniga.

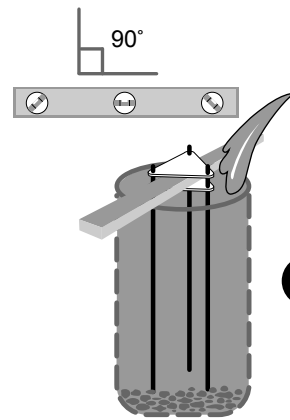

3

Aseta ankurkinnitus
lauale nii, et ankruplaat
jääks 2 cm betooni
tasapinnast kõrgemale.

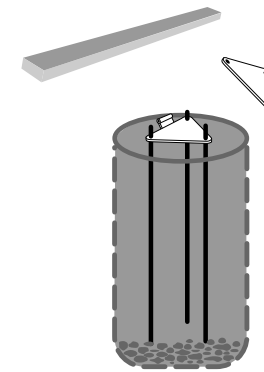

4

Lase betoonil ära
kuivada, peale mida
eemalda laud.

Ühenda hinge aasad
poldiga, tõsta mast üles
ning pinguta mutrid.



5

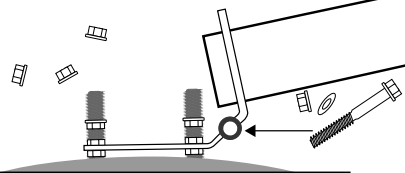

Reguleeri lipumast mutrite abil
püstloodi. Pinguta mutreid kuu aja
möödudes.

6

